

HI-SCAN™ 6040 CTiX Model S

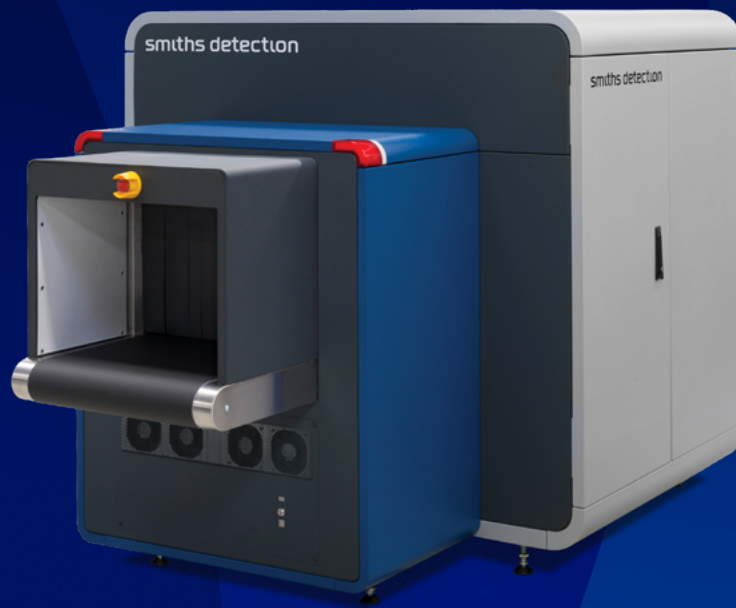

→ CT technology at the checkpoint

Featured Highlights

- Automatic explosives detection and object recognition
- Fast 0.2m/s belt speed
- Low energy consumption
- Minimal noise/zero vibration
- Optimized weight & footprint
- Highest certifications/approvals
- ECAC approved for screening liquids, aerosols and gels (LAGs) up to 2 liters

Certifications/ Approvals:

- Europe: ECAC EDS CB C3 for screening liquids, aerosols and gels (LAGs) up to 2 liters approved
- USA: TSA CPSS certified (Detection Standard APSS v6.2 level 1)
- France: STAC approved
- Italy: ENAC approved
- UK: DFT approved
- DGAC-STAC approved (France)
- TSA - ACSTL qualified (US)

Leveraging the latest Computed Tomography (CT) technology, the HI-SCAN 6040 CTiX Model S passenger checkpoint scanner delivers increased productivity; lower operating costs; and the highest standards of security [ECAC and STAC EDS CB3 approval as well as TSA APSS 6.2 Level 1 certification].

The overall screening process is streamlined to improve security outcome, operational efficiency and the customer experience. Eliminating the need to remove electronic devices, liquids and gels from hand luggage reduces the number of trays per passenger and speeds up divesting. A 0.2m/s conveyor belt drives throughput and high quality and 3D X-ray images help operators to make fast and accurate decisions. The HI-SCAN 6040 CTiX Model S user interface received the 2020 Red Dot award for fast and intuitive 3D image evaluation.

In addition to automatic explosives detection algorithms, the optional iCMORE automated object recognition software enables the HI-SCAN 6040 CTiX Model S to detect an expanding list of prohibited items including guns and knives.

The latest data security features and controls ensure customer data and assets are well protected from cyber-attacks. They include operating system hardening, a host-based firewall and strong encryption algorithms. System integrity is constantly monitored for unauthorised changes.

Due to the considerable reduction in width by 20cm and weight by 350kg, the HI-SCAN 6040 CTiX Model S is easily integrated into existing Smiths Detection and third-party checkpoints as well as checkpoints with size and layout limitations. It has a single phase 120/230V power supply for installation in Europe, the USA, APAC region and around the world. At 2.8 kVA, energy consumption is reduced by 5%-20% compared to other scanners in this class. Noise levels under 60dB(A) plus zero vibration help maintain a more pleasant checkpoint environment.

Technical Data

Dimensions • weight	3300 (L) x 1470 (W) x 1624 (H) [mm] • approx. 2099 kg 129.9" (L) x 57.9" (W) x 63.9" (H) • approx. 4628 lbs
Operating temperature	0° - 40°C
Power supply CT	single phase 230 VAC +10% / -15% • 50 Hz / 60 Hz ± 3 Hz, 16 A single phase 120 VAC +10% / -15% • 50 Hz / 60 Hz ± 3 Hz, 30 A
Tunnel dimensions	620 (W) x 420 (H) [mm] • 24.4" (W) x 16.5" (H)
Conveyor speed	0.2 [m/s]
Sound pressure	< 60 dB(A)
Max. conveyor load even distributed	160 kg (352 lbs)
External dose rate	≤ 1 µSv/h (0,1 mrem)
Humidity	10% - 90% (not condensing)

Additional Features

Operator Training Software ¹⁾
Full Integration into Checkpoint.Evo^{plus}
3D TIP ¹⁾
Compatibility with aTiX Checkpoints

Optional Features

iCMORE

¹⁾ Requires Heimann Management Server HMS or integration with Checkpoint.Evo^{plus}

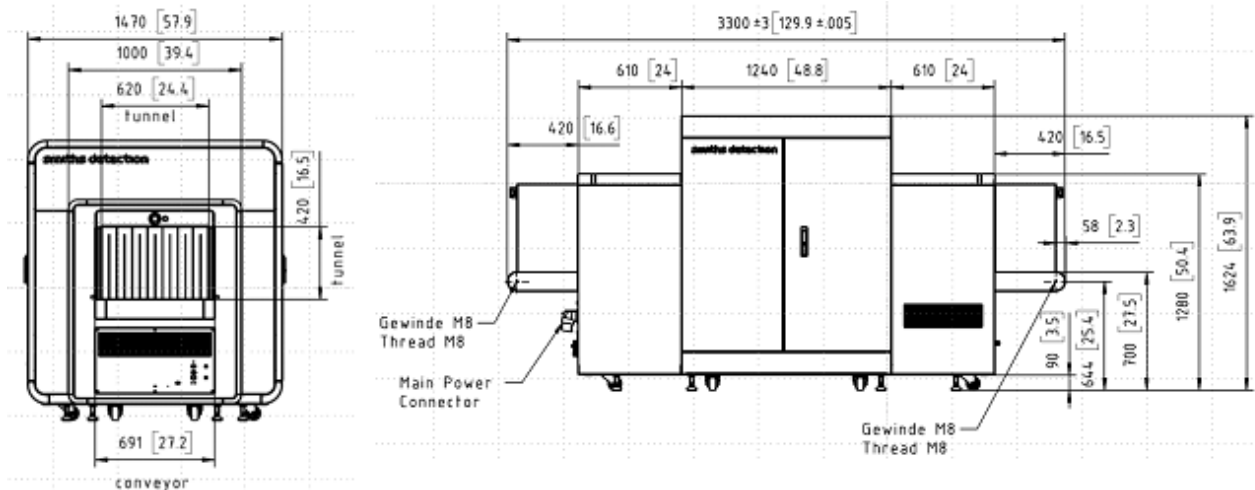

reddot winner 2020
interface design

For product information, sales or service, please go to www.smithsdetection.com/locations

Smiths Detection Germany GmbH, Im Herzen 4, 65205 Wiesbaden, Germany. Modifications reserved. 95597144 29/09/2025 © Smiths Detection Group Ltd. - In some cases, the figures contain options. HI-SCAN is a trademark of Smiths Detection Group Ltd.